

THE GEOMETRY OF MOVING STELLAR CONFIGURATIONS AND THE DATING OF THE *ALMAGEST*

V. V. Kalashnikov, G. V. Nosovskii, and A. T. Fomenko

1. The history of the question and the subject of this paper

Interest in the problem of dating the *Almagest*, the star catalog whose compilation is ascribed to Ptolemy, has a long history (cf., in particular, the survey in the fundamental study *The Crime of Claudius Ptolemy* by R. Newton [3] and also the work of C. Peters and E. Knobel [1]). This problem became particularly attractive after the famous astronomical observations of N. A. Morozov [9], who expressed well-founded doubts about the correctness of the traditional dating of the astronomical data of the *Almagest* to the second century C. E. (or the second century B. C. E.).

The investigations of A. T. Fomenko provided a new stimulus for a deeper study of this question (cf. the series of papers [10–15]). In this research the chronology of antiquity as a whole was analyzed on the basis of empirical-statistical methods proposed by Fomenko. The systematization of the results in the form of a global chronological chart was carried out by Fomenko in [16–18]. A large amount of critical material can be found in the book [3] of R. Newton mentioned above, where the conclusion is reached that the astronomical data in the *Almagest* were forged. In a recent work [19] Yu. N. Efremov and E. D. Pavlovskaya have attempted to confirm the traditional dating of the star catalog of the *Almagest* from the proper motions of the stars. This work, however, is based on faulty methodological assumptions and is mathematically illiterate. For more details on this see below.

The present work is devoted to the exposition of a new method of dating variable configurations formed on the celestial sphere by moving stars. Since the proper motions of stars have now been measured rather precisely, it is possible to compute their past positions in the heavens. Comparing these data with those of ancient star catalogs, one can attempt to establish the time of the star observation and, consequently the approximate time when the catalog was compiled. This method has been tested by the authors using several reliably dated star catalogs and a number of artificially compiled catalogs. In the case of the latter the “date of compilation” was, of course, known to the compiler, but not to the investigator! The effectiveness of the method was verified completely: the dates obtained using it practically coincided with the dates of compilation. This method was then applied to the star catalog of the *Almagest*. The results do not confirm its traditional dating.

The proposed method arose as the result of a careful analysis of the problem in its geometric, statistical, and computational aspects. The work was basically carried out in the years 1985–1987. It makes no attempt to address the questions involving analysis of sources or of historical character, and is purely geometric and computational. In the part that involves applying the method to dating specific catalogs we present only the results that were obtained by analysis of the numerical material collected in these catalogs, namely the star coordinates.

2. Necessary astronomical information

To explain the essence of the problem and the meaning of the results obtained systematically we remind the reader of a number of concepts from astronomy (cf. [3–5], and Fig. 1).

In observing the stars one assumes that they are located on the *celestial sphere*, whose center is the “observer’s eye.” To determine precisely the position of a star one must give some *spherical coordinate system*. In what follows we shall use two systems: the *equatorial* and the *ecliptic*.

The *equator* of the celestial sphere is the curve of its intersection with the plane of the terrestrial equator. Knowing the equator, one can introduce “parallels and meridians” on the celestial sphere. The

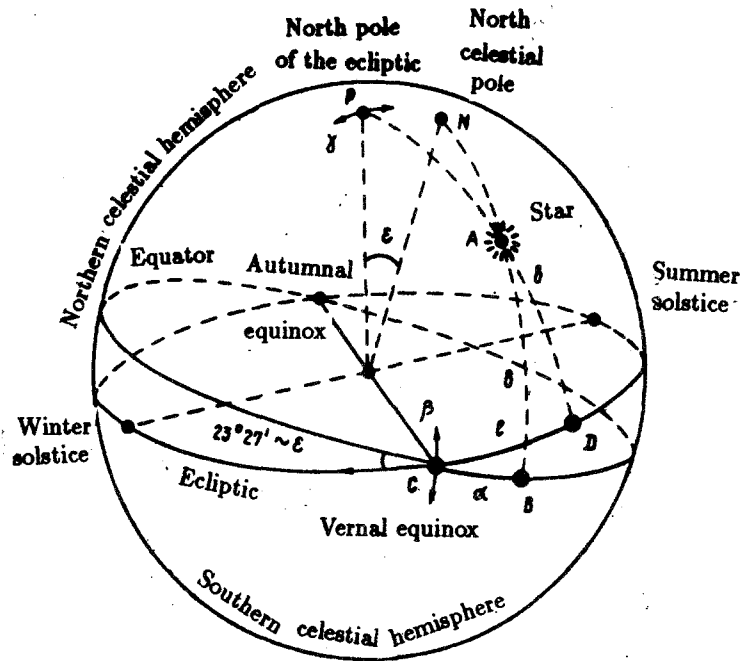

Fig. 1

latitude of a parallel (measured in degrees of arc and denoted by δ below, $\delta \in [-90^\circ, 90^\circ]$) is called the *declination* of the star. The position of the meridian (measured in hours and denoted α , $\alpha \in [0, 24h]$) is called the *right ascension* of the star. To be completely definite one should also indicate the point from which right ascension is measured. We shall do this shortly.

The *ecliptic* is the curve of intersection of the celestial sphere with the plane of the Earth's orbit around the Sun. The *zodiacal constellations* are ranged along the ecliptic. If we now consider the ecliptic as the analog of the terrestrial equator, we can define "parallels and meridians." The latitude of the parallel so constructed is called the (ecliptic) *latitude* of a star. We shall denote it by b and measure it in degrees of arc, $b \in [-90^\circ, 90^\circ]$. The position of the "meridian" on which a star is located is called its *ecliptic longitude*. We shall denote it by l and measure it in degrees $l \in [0, 360^\circ]$. As in the case of equatorial coordinates, in this case it is necessary to define the position of the "zeroth meridian." The intersection of the planes of the equator and the ecliptic is called the *equinoctial axis*; it intersects the celestial sphere at the vernal and autumnal equinoxes. The *vernal equinox* is taken as the point from which both right ascension and ecliptic longitude are measured.

The two coordinate systems just introduced are not fixed; on the contrary, they vary with time in accordance with the following three principles.

A) The axis of rotation of the Earth (the radius-vector ON in Fig. 1) *precesses* with a velocity of about 50 seconds of angle per year, i.e., it moves approximately on a cone whose aperture (i.e., the angle between ON and OP) is about $23^\circ 27'$ (for the year 1900). The axis ON makes one complete revolution in approximately 26,000 years. As a result the equatorial coordinate system also "precesses," and the equinoctial axis (and consequently the point from which ascensions and longitudes are measured) shifts (*precession of longitude*) clockwise when viewed from the north celestial pole (cf. the arrow C in Fig. 1). Thus if we take some fixed point on the celestial sphere, for example, a fixed star, we find that its right ascension is a function of time $\alpha(t)$ corresponding to a "nearly" uniform motion along a circle parallel to the ecliptic.

B) Besides its precession the Earth's axis is subject to small oscillations called *nutations*, whose maximum amplitude is about $17''$.

C) Another variation—the *oscillation of the ecliptic*—is caused by the variation of the plane of the earth's orbit over time. We shall denote by $\varepsilon(t)$ the angle formed by the planes of the equator and the

ecliptic (Fig. 1). The relation $\varepsilon(t)$ describes the oscillation of the ecliptic as a function of time.

In our computations we have taken account of precession of longitude and the oscillations of the ecliptic and have ignored such small oscillations as nutations. A precise astronomical and mathematical theory of the motion of the ecliptic was developed by S. Newcomb. It has been generally accepted up to the present time and is the basis for all computations connected with the evolution of the ecliptic and other parameters of motion of the Earth. We have relied on this theory and also on the modern precise equations for computing the functions $\alpha(t)$ and $\varepsilon(t)$ [6]. Newcomb's theory is the basis for the work of Peters, Knobel, R. Newton, and other astronomers.

The third effect that we have taken into account in our research is the presence of noticeable proper motions of certain stars. Actually we have regarded all the stars without exception as moving. The data on the size and directions of the velocities are given in the fundamental star catalog FK4 of [7]. The majority of stars have a small velocity, but there are stars that have changed their positions in the sky by several degrees over 2000 years as a result of proper motion. Since we are interested in the interval of 2500 years from our time to 500 B. C. E., we can assume that in this interval the trajectories of the stars on the fixed sphere are segments of great circles.

Finally, in observing the stars of low latitude, we have taken account of the effect of refraction.

In our computations the time parameter t is measured in centuries and is chosen as follows. The value $t = 0$ corresponds to the year 1900 (the year for which the coordinates of the "modern" stars are given), $t = 1$ corresponds to 1800, etc. This parameter is not necessarily a whole number. Thus, the value $t = 3.75$ corresponds to the year 1525. In specific computations the parameter t varied within a certain a priori interval. For example for the *Almagest* this interval was taken as $0 \leq t \leq 25$.

3. Some peculiarities of the extant star catalogs

In what follows we shall be discussing the star catalogs of Ptolemy, Tycho Brahe, Ulug Beg, and Hevelius, which were compiled without the aid of a telescope. Each of them contains more than a thousand stars. The ancient catalogs use ecliptic coordinates. This is probably explained by the fact that the ancient astronomers did not know about the small oscillations of the ecliptic and consequently considered ecliptic coordinates "permanent," i.e., such that the latitudes of the stars would not vary with time, while the longitudes would vary with a constant velocity as a result of precession.

Modern catalogs contain data on approximately 5000 stars visible to the naked eye. These catalogs are compiled in equatorial coordinates, which are simpler to measure than ecliptic, and therefore more reliable.

A number of stars in the catalogs are assigned names—the *named stars*. As a rule these are the bright stars, some of which are fast-moving, for example, Arcturus. It is reasonable to assume that the compiler of a catalog gave names to those stars whose position on the celestial sphere was measured with particular care. For this reason we shall call the set of named stars of a catalog its *informational kernel*. This name will receive additional justification below, based on specific computations. The informational kernels may vary from one catalog to another, but in the catalogs mentioned above they are very close to one another and in any case contained in one another. The named stars form a prominent basis (system of reference points) on the celestial sphere from which it is convenient to measure the positions of other stars not endowed with special names.

For dating purposes the question of the *precision of the data of a catalog* is vital. In a number of catalogs (the *Almagest* and that of Tycho Brahe) the precision is indicated explicitly. Thus in the *Almagest* the divisions are at intervals of $10'$ and in that of Tycho Brahe at intervals of $1'$. In the catalogs of Ulug Beg and Hevelius, on the other hand, one can judge the precision only indirectly, based on the written data. As an example let us say that in the catalog of Hevelius [8] the coordinates of the stars are given with a precision of $1''$.

Numerous studies attest that the question of precision must be approached with care. Thus, it was shown by statistical methods in [3] that the errors in the latitudes of stars in the *Almagest* are about $20'$ (not $10'$) and the error in arcwise deviation is $1^\circ 12'$. The latter contains a systematic bias, whose removal reduces the error to $22'$. The precision of Tycho Brahe's catalog is taken by the latest investigators to be $2'-3'$, which agrees with our own results. By the logic of things the precision of the catalog of Hevelius

cannot be 1". It must be comparable to the precision of Tycho Brahe's catalog, since the two used exactly the same instruments.

4. Errors in the coordinates of the ancient catalogs

The reasons for the occurrence of errors in the ancient catalogs were discussed by R. Newton in [3]. For what follows we must pay attention to the following circumstances. Starting from the methods of making specific measurements (cf. [3, 4]), it is natural to assume that for the ancient catalogs the *discrepancy in latitude* obtained as a result of inaccuracy in measurement is less than the discrepancy in longitude, and naturally less than the *arcwise discrepancy*. Consequently the latitudes are the most precisely measured coordinates of the stars. This assumption is confirmed by an analysis of the catalogs.

The *arcwise discrepancy* may contain additional components as a result of later recomputations of the catalogs to eliminate the effect of precession (cf. [3]).

The compilers of the catalogs did not know about the phenomenon of *refraction* and the effect of error accumulation in measuring coordinates using reference points. Errors resulting from these causes undoubtedly occur in the catalogs.

Errors also arose in the copying of the catalogs (for example, the *Almagest* was compiled without using number signs, thus increasing the possibility of an incorrect interpretation of what was written).

Hence if the errors in coordinates are interpreted as random, then within the limits of the claimed precision of a catalog, it is natural to regard this error as a quantity taken from some homogeneous sample (for example a normal sample). "Large deviations" or "spurious data" can result from the causes listed above and a hypothesis of randomness in regard to them is in general unnatural. In analyzing a catalog one should strive to isolate such "doubtful" stars so as not to base any final conclusions on them. Peters and Knobel, for example [1], discuss numerous doubtful cases, and we have taken these discussions into account.

5. A preliminary analysis of the *Almagest*

Our initial list is the *Almagest*, which contains more than a thousand stars, in the form given by Peters and Knobel [1]. The list of stars analyzed includes a number of variant coordinates given in [1]. At the preliminary stage the star coordinates of the *Almagest* were not subjected to any doubt, nor was the fact that they are given in ecliptic coordinates referred to the year 60 C. E.

Peters and Knobel [1] give an identification of the stars of the *Almagest* with modern stars. Nevertheless in selecting stars for subsequent analysis, we did this identification over again. For this purpose we took out of a modern catalog a list consisting of 30 named stars and 50 rapidly-moving stars. In answering the question "Who's who?" on the basis of S. Newcomb's theory (cf. Sec. 2 above) using a computer at the times $t = 1, 2, \dots, 25$ we computed the coordinates of all the stars of this list and compared them with the coordinates given in the *Almagest*. In most cases the correctness of the identification of the stars given in [1] was confirmed, and the pairs of identified stars so obtained were classified according to the magnitude of the arcwise distance between them. However several stars in the modern catalog were discovered (in particular α_2 Eridan) for which different stars of the *Almagest* were identified at different times. Thus for α_2 Eridan these were the stars having Bailey numbers 778, 779, and 780. We remark that doubt is also expressed about the identification of this star in [1]. Nevertheless, it was precisely the motion of the star α_2 Eridan that was used to draw conclusions about the dating of the *Almagest* in the paper of Efremov and Pavlovskaya.

Carrying out the identification procedure yielded a table T whose rows contain the following data on all the identified pairs: (1) the Bailey number i ; (2) the right ascension α_i and declination δ_i of the star from the modern catalog at the time $t = 0$; (3) the components of the velocity of the motion of the star on the celestial sphere; (4) the longitude l_i and latitude b_i of the corresponding star from the *Almagest*.

We shall denote the equatorial coordinates of the i th star at time t from the modern catalog by $\alpha_i(t)$ and $\delta_i(t)$ and the ecliptic coordinates by $L_i(t)$ and $B_i(t)$ computed while taking account of precession and the oscillation of the ecliptic. The problem is to find a value of t for which the set of coordinates

$V(t) = (L_i(t), B_i(t))_{i \geq 1}$ or $W(t) = (\alpha_i(t), \delta_i(t))_{i \geq 1}$ is in best agreement with the set $V_A = (l_i, b_i)_{i \geq 1}$. The apparent simplicity of the statement of the problem rests on difficulties that it is the purpose of this paper to overcome.

A problem of this sort is standardly solved by giving some natural distance between the sets $V(t)$ and V_A (or $W(t)$ and V_A) and a choice of dating time t^* starting from the minimum of this distance. This is precisely the approach of Efremov and Pavlovskaya [19]. However, the possible error in determining t^* by this method is too large. Suppose, for example, $a_i(t)$ is the arcwise distance between the coordinates $(L_i(t), B_i(t))$ and (l_i, b_i) , and let $t_i^* = \operatorname{argmin} a_i(t)$. It is easy to appreciate that if in the determination of the position of a star in the *Almagest* there is an arcwise error Δ and v_i is the velocity of the star with index i on the celestial sphere (more precisely, the projection of this velocity on the line joining the coordinates of the stars from the modern catalog and the *Almagest*), then one can conclude only that the date t belongs to the interval $(t_i^* - \frac{\Delta}{v_i}, t_i^* + \frac{\Delta}{v_i})$. Now by the most optimistic estimate for the *Almagest* $\Delta \approx 14'$ (the hypotenuse of a triangle with legs of $10'$, the claimed precision of the *Almagest*), and $v_i \approx 1.5''/\text{year}$ for a very fast-moving star (Arcturus). We find that the length of the interval of possible datings for this case is 1200 years. For more slow-moving stars the length of this interval covers all the values $0, \dots, 25$.

Numerical computations confirmed the low precision of such methods. The computed values of t_i^* for different stars and the analogous quantities for various configurations were distributed quite uniformly over the interval from $t = 0$ to $t = 25$. In addition we noticed a variability in the results obtained according to the kind of distance used, i.e., the essentially subjective character of the result. We discovered an effect that is completely inexplicable with such an approach: in the computations the distance between stars of the modern catalog and the *Almagest* was on the average smaller when we did not take account of the oscillation of the ecliptic than when we did take account of it.

Efremov and Pavlovskaya [19] base their dating of the *Almagest* formally on the comparison of two pairs of configurations (*Almagest*–modern sky), each of which contains a fast-moving star (Arcturus and o_2 Eridan). In doing this, they were essentially comparing the positions of a fast star in the *Almagest* and in the modern sky in relation to the other stars in the configuration (i.e., to the vicinity of the star). Such an approach enabled them to avoid recomputing the coordinates of the stars and basing their conclusions on Newcomb's theory, but sharply worsened the precision of the method (about which nothing is said in [19]), since dozens of faint stars in the vicinity measured with the characteristic error of the *Almagest* ($15'$ – $30'$) are clearly not sufficient to give a precise determination of the position of a fast-moving star. We note also that varying the set of stars in the configuration of Arcturus considered in [19] makes it possible to vary the date obtained from $t^* = 13$ to $t^* = 21$ ($t^* = 16.5$ in [19]). Furthermore Efremov and Pavlovskaya arrive at the conclusion that Arcturus was measured significantly less accurately by Ptolemy than o_2 Eri and actually reject the data for Arcturus, basing their final conclusion essentially on the configuration of o_2 Eri. But the identification of this faint star with No. 779 in the *Almagest* (there called simply the "Middle Star") is, first of all, not accepted by all researchers (cf. the table of identifications in [1]), and second, depends essentially on an a priori dating of the catalog (cf. above). For that reason the dating of the *Almagest* in [19] is based on an a priori dating of the catalog by an epoch near the beginning of our era (for other epochs the star o_2 Eridan is identified with other stars of the *Almagest*). The mathematical level of [19] is shown most eloquently by the fact that the authors used random perturbations of the configurations to "sharpen" the coordinates of the stars. It follows from the law of large numbers, however, that in the best case (with a linear relation between the characteristics of the perturbed coordinates) the data obtained will be close to the unperturbed data, and in the worst case (nonlinear dependence) the data lead to a systematic error.

It is also of interest to note the following fact. The informational kernel of the *Almagest* consists of the following twelve stars, which are given the designation *vocatur*, i.e., *called*, in the text (the astronomical names and Bailey numbers are given in parentheses): Arcturus (α Boo, 110), Sirius (α CMa, 818), Altair (α Aql, 288), Prevedemiantrix (ε Vir, 509), Antares (α Sco, 553), Aselli (γ Cnc, 452), Procyon (α CMi, 848), Regulus (α Leo, 469), Spica (α Vir, 510), Vega (Lyra) (α Lyr, 149), Capella (α Aur, 222), Canopus (α Car, 892). Table 1 contains the information on the declinations (in minutes) of latitude $|B_i(t) - b_i|$ for these stars for some values of t . The values $t = 18$ and $t = 21$ correspond almost exactly to the traditional dates of the lives of Ptolemy and Hipparchus—in some accounts [3, 19] the *Almagest* is ascribed to Hipparchus.

The data presented give a clear illustration of our assertion stated above that it makes no sense to date the catalog from the minimum distance between some stars or star configurations. It is clear from the table that for 7 stars (of the 12) the quantity $|B_i(t) - b_i|$ never attains $10'$ (the claimed precision of the *Almagest*) for $1 \leq t \leq 21$. For the star with number 510 the inequality $\max |B_{510}(t) - b_{510}| < 10'$ holds. Of the other four stars at most two fall into the $10'$ interval at any given time. And this applies to the named stars, i.e., those whose coordinates the compiler of the catalog must have measured with special care!

Table 1

	1	5	10	15	18	21
110	37.6	21.2	0.9	19.3	31.4	43.3
818	23.6	18.3	11.7	5.1	1.2	2.6
288	8.6	9.4	10.5	11.8	12.6	13.4
509	13.0	14.3	15.8	17.1	17.8	18.4
553	32.6	29.5	25.5	21.6	19.3	17.0
452	30.5	28.5	25.9	23.2	21.5	19.8
848	11.2	16.0	21.9	27.6	31.1	34.4
469	17.5	16.6	15.4	14.0	13.0	12.1
510	2.4	0.7	1.3	3.1	4.2	5.2
149	15.4	14.2	12.5	10.8	9.8	8.7
222	21.9	21.7	21.3	21.0	20.8	20.6
892	51.0	54.2	58.2	62.3	64.8	67.3

It is of interest to note that the same picture emerges for catalogs having a reliably known date of compilation, for example, that of Tycho Brahe.

6. General description of the proposed method of analysis

6.1. *Types of errors in the catalog.* After carrying out the preliminary stage we are in possession of the table T , which contains information on the coordinates and velocities of the pairs of stars identified between the modern and ancient catalogs. It has been shown that the date of an ancient catalog cannot be determined merely by comparing precisely computed coordinates of the "modern" stars with the coordinates in the ancient catalog. This is explained primarily by the large errors in the ancient catalog, cf. Sect. 4. For that reason only a careful accounting for the different kinds of errors can produce success.

We classify the errors into three types: systematic, random, and "spurious."

We classify as errors of the first type all the distortions of data that lead to shifting the whole set of stars as a group on the celestial sphere.

Random errors are caused mostly by errors in measuring within the limits of precision of the scale of the measuring device (this scale may or may not be known to us). These errors are characterized by shifting each star on the celestial sphere by a random amount with zero mean.

The "spurious" errors arise because of circumstances unforeseen by or unknown to the compiler (copy errors, refraction, and the like). They also affect only the coordinates of individual stars and their magnitudes, as a rule, are noticeably larger than the precision of the scale of the measuring instrument. The errors themselves are rather rare.

6.2. *Systematic errors.* Systematic errors arise mainly from two causes. The first is the conversion from equatorial to ecliptic coordinates carried out by the ancient astronomers. This conversion had to be made, since the measuring instruments were attached to a terrestrial coordinate system. The conversion to the ecliptic system was carried out either using trigonometric formulas or by instruments using large celestial

globes, astrolabes, and the like. To make such a conversion the compiler of the catalog had to know the position of the equinoctial axis OC for the year t by which he was dating his catalog. In general he knew this position imprecisely, with an error τ_1 . Furthermore, the compiler might make an error in determining the longitude of the stars. Let us denote this error by τ_2 . Since these two errors add (cf. Sec. 2), it suffices to consider just the total error in longitude, denoting it by $\tau = \tau_1 + \tau_2$.

The next possible error consists of moving the point C from the equator with respect to latitude. This error is denoted β in Fig. 1 and in the text below.

By introducing the quantities τ and β we have given a complete description of all possible deviations of the point C on the sphere: any error is a combination of these two.

The third error is in the determination of the angle ε between the equator and the ecliptic (cf. Fig. 1). We shall denote it by γ . In other words, γ is the error in the determination of the pole of the ecliptic on the sphere.

The β and γ , whose values were chosen in the process of computing by sampling (both with replacement and without), were introduced with the intention of taking account of the types of errors just enumerated.

It is easy to see that any rotation of the sphere can be resolved into three orthogonal rotations, determined by the parameters τ , β , and γ . Therefore one can formally include systematic errors of measurement in them also if any such errors exist.

The possibility that systematic errors might be present has been discussed by many investigators [1, 3, 9], and we mention here the probable causes of such errors.

The error τ might be caused by an observer or later reader of the catalog "updating the catalog" to a date that is different from that of the actual observation. Such an updating sometimes served purposes that were probably methodological (for example an attempt to update the catalog to some round calendar year), sometimes served to mask the actual date for the observation and the referral of the catalog to a different epoch [3], and sometimes was a consequence of changing the reference point from which longitudes were computed: the ancient astronomers could generally compute longitudes from various points on the ecliptic. Such a change in reference point naturally led to the addition of some constant to all ecliptic longitudes.

What can be said about the nature of the errors β and γ ? Since the equatorial latitudes of stars are determined by direct observations quite simply and precisely [4], one should expect that for an accurate observer the error β should be practically zero at the time of his observation. In other words, it is most likely that $\beta \approx 0$. The error γ is fundamentally different. A determination of the position of the ecliptic is the result of complicated computations or non-trivial measurements. Consequently the order of error of γ must be significantly larger than the order of the error in β . In [1] and [9] there are hints that there is a systematic error in γ in the *Almagest*. Moreover a number of authors estimate its size at $20'$. As we shall see, our computations confirm this fact.

6.3. Random errors and spurious data. Consider a star with Bailey number i from the table T mentioned above. Let l_i and b_i be ecliptic coordinates of the star with this number in the *Almagest*, and $L_i(t, \tau, \beta, \gamma)$ and $B_i(t, \tau, \beta, \gamma)$ its longitude and latitude obtained as follows from the equatorial coordinates α_i and δ_i for star i in a modern star catalog: we find the value of the right-ascension $\alpha_i(t)$ and declination $\delta_i(t)$ at time t and convert these to ecliptic coordinates $L_i(t)$, $B_i(t)$. We then "rotate" the ecliptic through the angles of the systematic errors β and γ and change the longitude by the amount τ , regarding these as known, cf. Sec. 6.4. We then obtain the values of the coordinates of the i th star in the "perturbed" ecliptic system, i.e., in the system in which the coordinates of the stars are written in the *Almagest*: $L_i(t, \tau, \beta, \gamma) = L_i(t, \beta, \gamma) + \tau$; $B_i(t, \beta, \gamma)$. It is clear that the latitude is independent of the error τ . This is one of the reasons for the greater reliability of the latitude coordinates. It is precisely for that reason that we shall work primarily with them below, using information on the longitudes only as an aid.

We introduce the following deviations with respect to latitude and longitude:

$$\Delta_b(i, t, \beta, \gamma) = B_i(t, \beta, \gamma) - b_i, \quad \Delta_l(i, t, \tau, \beta, \gamma) = L_i(t, \tau, \beta, \gamma) - l_i.$$

If no unforeseen errors are added to the measurements of the star with index i (refraction, scribal errors, and the like), then these deviations must lie within the interval of precision characteristic for the

given catalog. As already noted, the precision of a catalog may be unknown or exaggerated. The author of a catalog could have taken as his limit of precision the "record" precision he achieved in measuring the coordinates of the most prominent stars. For that reason, in order to filter out the stars whose coordinates contain "spurious data," one must use the following method, in which the quantities β and γ are regarded as known:

1) estimate the actual precision of the catalog, using the mean-square deviation

$$\sigma = \left[\left(\sum_i \Delta_b^2(i, t, \beta, \gamma) \right) / N \right]^{1/2},$$

where N is the number of stars in the table T ; since the majority of stars have a small velocity of proper motion, the quantity σ is practically independent of t : it is perfectly possible to take the quantity σ so obtained (or even $\frac{\sigma}{2}$) as the "record" precision Δ of the catalog. The "actual" precision of the catalog is $2\sigma-3\sigma$; we note that about 40% of the stars fall in the interval of "record" precision;

2) the stars whose coordinates do not fall within the given "record" precision, are excluded from further consideration—they include stars measured with errors that are too large, or "spurious" stars.

We make the following remark. In determining the quantity σ the "spurious" stars exert very little influence because there are so few of them. However, in our work we excluded a priori from the table T those stars about whose coordinates any kind of doubt was expressed in [1]. At this stage one can eliminate from consideration the stars for which refraction plays a large role in the determination of the coordinates—cf. the star Canopus in Table 1. The determination of the "record" precision makes it possible to continue the work with coordinates that were measured with extreme care. In particular, it is natural that the majority of stars of the informational kernel must be such stars. If the parameter t played only a minor role in the estimate of σ , then in excluding stars from the table T one must approach them individually and exclude those for which $\min |\Delta_b(i, t, \beta, \gamma)| > \Delta$. Thus if we take $\Delta = 10'$, $\beta = \gamma = 0$, then one must exclude the stars with indices 509, 553, 452, 848, 469, 222, and 892 from the list of stars in Table 1.

6.4. *Estimating the systematic errors.* The quantities β and γ that determine the possible error in the position of the ecliptic can be estimated from the data of ancient and modern catalogs by various methods. We shall discuss here a statistical method based on the law of large numbers, which does not exclude the possibility of using other methods.

Consider a certain collection of stars X from the table T . We denote by n the number of stars in this collection and suppose that X consists mostly of fixed stars. Let t^* be the true date of the catalog (unknown to us) and ω the angular velocity of revolution of the equinoctial axis, i.e., the velocity of precession, and let β and γ be the true values of the errors committed by the compiler of the catalog at time t^* . Since the angles β and γ determine the position of the north pole of the ecliptic in the year t^* and since the true position of the equinoctial axis in year t is unknown to us, it follows that, if we wish to date the catalog by the year t , starting only from the correctness of the position of the north pole, we would have to ascribe to the compiler of the catalog the errors $\gamma(t) \approx \gamma \cos \omega(t - t^*) - \beta \sin \omega(t - t^*)$, $\beta(t) = \beta \cos(\omega(t - t^*)) + \gamma \sin \omega(t - t^*)$. On the a priori time interval for the *Almagest* we have $|\omega(t - t^*)| < 30^\circ$, but in reality one should assume $|\omega(t - t^*)| < 15^\circ$. For the catalogs of Tycho Brahe and others this quantity is of lower order. This results in the possibility of determining the quantities β and γ , within the limits of precision required for our computations (for the *Almagest* this is $5'$), by averaging the values given above over t . By the definition of a systematic error (the absence of translation) the desired quantities $\beta(t)$ and $\gamma(t)$ must satisfy the condition

$$\bar{\Delta}_X = \frac{1}{n} \sum_i \Delta_b(i, t, \beta(t), \gamma(t)) \approx 0. \quad (1)$$

If the number n is sufficiently large, relation (1) can be understood in the sense that $|\bar{\Delta}_X| \leq \frac{\sigma}{\sqrt{n}}$. However relation (1) is insufficient to determine β and γ . We consider also the quantity

$$\sigma_X = \left[\left(\sum_i (\Delta_b(i, t, \beta(t), \gamma(t)) - \bar{\Delta}_X)^2 \right) / (n - 1) \right]^{1/2}. \quad (2)$$

The behavior of the quantities $\bar{\Delta}_X$ and σ_X is determined to a large degree by the choice of the set X .

A. Suppose the stars in the collection X are rather uniformly distributed over longitudes, for example, the zodiacal stars. Then it is easy to see that the quantity $\bar{\Delta}_X$ will depend weakly on β and γ . In fact, if the latitude of a star with longitude l varies by the amount ε , then the latitude of a star with longitude $(l + 180^\circ) \pmod{360^\circ}$ varies by the amount $-\varepsilon$. Here the unknown quantities β and γ are found from the relation

$$(\beta, \gamma) = \operatorname{argmin} \sigma_X. \quad (3)$$

B. If the set X is distributed rather compactly on the celestial sphere, for example the stars of one sign of the Zodiac, then the quantity σ_X will depend weakly on β and γ , since a rotation of the ecliptic will cause nearly the same change in latitudes and longitudes for all the stars of X . In this case one must take

$$(\beta, \gamma) = \operatorname{argmin} |\bar{\Delta}_X|. \quad (4)$$

C. If the set of stars X is distributed rather compactly near the longitudinal values 0° or 180° , then the quantity $\bar{\Delta}_X$ will depend weakly on γ and in contrast strongly on β . If this set is located near the longitudinal values 90° or 270° , then the quantity $\bar{\Delta}_X$ is sensitive to a change in γ and insensitive to a change in β .

The relations (3) and (4) and the peculiarities of behavior of $\bar{\Delta}_X$ and σ_X just enumerated make it possible to determine β and γ many times with different choices of the set X , thus increasing the reliability of estimates of them.

In the process of calculating β and γ in relations (3) and (4) on the computer, the sizes of these quantities were determined by sampling. When this was done, it was found that $\beta = 0$ within the limits of computational precision. For an addition justification of this fact see Sec. 7.

The total error in longitude τ can be estimated after β and γ have been found. To do this one must take as τ the estimate

$$\hat{\tau}(t) = \frac{1}{n} \sum_i (l_i - L_i(t, \beta, \gamma)), \quad (5)$$

which gives the value of the possible systematic error in τ for each t . In contrast to β and γ , the quantity $\hat{\tau}(t)$ depends "strongly" on t (see the discussion of precession in Sec. 2). Therefore the estimate of $\hat{\tau}(t)$ is not very informative, and its size shows only the extent to which the time t differs from the time t^{**} at which $\hat{\tau}(t^{**}) = 0$. For the *Almagest*, for example, $t^{**} = 18.4$ —the date to which the longitudes were adapted by changing them by some constant [1]. Nevertheless the following function can give some information:

$$\bar{\tau}(t) = \max_i (l_i - L_i(t, \beta, \gamma)) - \min_i (l_i - L_i(t, \beta, \gamma)). \quad (6)$$

This function characterizes the spread of the longitudes of the stars of the ancient catalog about hypothetically "true" values under the assumption that the date of compilation of the catalog is determined by the time t .

6.5. *Dating a catalog.* After the systematic errors β and γ are estimated, it is necessary to date the catalog using the coordinates of the more precisely measured stars (see Sec. 6.3). We denote this set of stars by E .

Since the majority of stars are "nearly fixed," basing the algorithm for dating only on the proper motions of stars leads to the study of only two stars (Arcturus and Procyon). Computations show that in none of the catalogs under consideration are they badly measured by the criteria of Sec. 6.3 (in contrast to another rapidly-moving star—Sirius). Therefore one of the methods of dating is to exhibit the interval T_1 determined by the relation

$$T_1 = \{t : \max(|\Delta_b(110, t, \beta, \gamma)|, |\Delta_b(848, t, \beta, \gamma)|) \leq \Delta\}, \quad (7)$$

where Δ is the precision of the catalog (cf. Sec. 6.3).

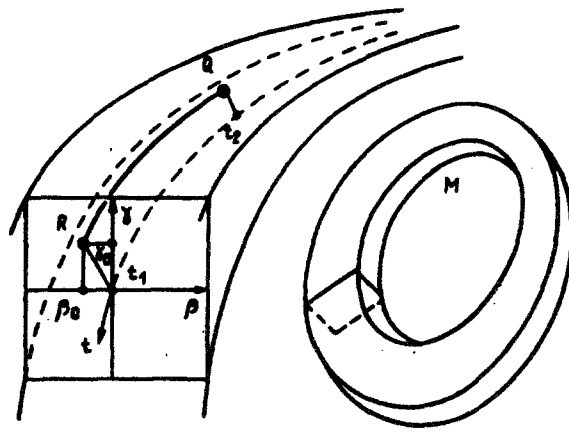

Fig. 2

Another method of dating relies essentially on the fact that the ecliptic oscillates and is applicable to fixed stars.

We denote by $N(t)$ the number of stars in the set E for which the inequality $|\Delta_b(i, t, \beta, \gamma)| \leq \Delta$ holds, i.e.,

$$N(t) = \#\{i; |\Delta_b(i, t, \beta, \gamma)| \leq \Delta\}, \quad (8)$$

and let $\bar{N} = \max N(t)$, where the maximum is taken over the a priori time interval (cf. Sec. 2). As the set of times dating the catalog we take

$$T_2 = \{t : N(t) = \bar{N}\}. \quad (9)$$

If the set T_1 is an interval, then the set T_2 can theoretically be the union of some number of disjoint intervals ("solutions").

The following considerations can give additional information on the true date t^* of compilation of the catalog. For each t consider the set of values $\{|\Delta_b(i, t, \beta, \gamma)|\}_{i \in E}$. From this set one can construct the distribution function for the errors

$$F^{(t)}(x) = [\#\{i : |\Delta_b(i, t, \beta, \gamma)| \leq x\}] / [\#\{E\}], \quad (10)$$

and also the empirical mean and variance respectively

$$\bar{\Delta}_E(t) = \left[\sum_{i \in E} |\Delta_b(i, t, \beta, \gamma)| \right] / [\#\{E\}], \quad (11)$$

$$\sigma_E^2(t) = \left[\sum_{i \in E} \{|\Delta_b(i, t, \beta, \gamma) - \bar{\Delta}_E(t)|^2\} \right] / [\#\{E\} - 1]. \quad (12)$$

It is natural to assume that the functions $\bar{\Delta}_E(t)$ and $\sigma_E(t)$ will attain their minimum values near the time t^* , and that $F^{(t^*)}(x) \geq F^{(t)}(x)$, $0 \leq x \leq 2\Delta$, for all t .

Thus having several criteria for the time of dating, one can confidently date the catalog. The results of applying this method to the dating of actual and artificially compiled catalogs are given below.

7. The compatibility of star positions in ancient and modern catalogs

The methodology discussed in Sec. 6 is based on a number of ideas as to the errors committed by the compiler of the ancient catalog, and its result is a definite time interval containing the date of observations of the stars in the catalog. It is natural to expect that under different sets of parameters β , γ and t the mutual location of stars from the ancient and modern catalogs would be worse, but this by no means follows from the methodology of Sec. 6. For that reason we also verified the "converse" assertion, which is also true.

Consider the set of stars D from the informational kernel, “purged” of the spurious data that manifested themselves under all possible values of β and γ . Let

$$\Delta_b(D, t, \beta, \gamma) = \max_{i \in D} |\Delta_b(i, t, \beta, \gamma)|. \quad (13)$$

Consider the three-dimensional group of orthogonal proper rotations of three-dimensional space, usually denoted SO_3 . Let $g(t, \beta, \gamma)$ be the parametric family of transformations from this group that convert ecliptic coordinates at the time $t = 0$ to ecliptic coordinates at time t while taking account of the rotation of the ecliptic in the year t by the angles β and γ . Geometrically this set of transformations can be represented as a three-dimensional “tube” M in the orthogonal group SO_3 (Fig. 2). The t -coordinate varies along the axis of the tube and a representative point on this axis describes a circle whose perimeter corresponds to the variation of the parameter t from 0 to 260 (i.e., over the period of precession). The other two parameters β and γ can be regarded as coordinates in the normal plane that cuts the tube at the time t . The perturbations β and γ can be considered comparatively small, so that the tube in Fig. 2 is drawn with a rather narrow normal section. We use the notation

$$\Delta_b(D, t) = \min_{\beta, \gamma} |\Delta_b(D, t, \beta, \gamma)|, \quad (14)$$

$$\Delta_b(D) = \min_t \Delta_b(D, t). \quad (15)$$

Taking account of the interpretation given above, we may assume that the minimum in relations (14) and (15) is taken over all transformations $g(t, \beta, \gamma)$ of the t -section of the tube M and all $g \in M$ respectively. We further assume that the minimum of the function $\Delta_b(D, t)$ is attained strictly inside the tube M . Since all the computations are carried out approximately, the minimum is attained not at a single point (t_0, β_0, γ_0) but on some curve lying inside the tube M . We assume that this curve (in Fig. 2 it is drawn as the boldface arc with endpoints R and Q) not only lies entirely inside the tube M , but that the parameters β and γ are practically constant along it, i.e., the curve is parallel to the axis of the tube. Then we may assume that this curve determines β_0 , γ_0 , and a time interval T' from t_1 to t_2 on the t -axis uniquely (Fig. 2). If the values of β_0 and γ_0 happen to coincide with those found by the method of Sec. 6, we obtain an additional confirmation of the correctness of our determination of the systematic errors β and γ and also the interval T' of possible dates for the catalog. Moreover we prove that the ecliptic coordinates of the stars were indeed measured by the observer by the method described above (i.e., the equatorial coordinates were measured first and then converted to ecliptic coordinates by a “rotation” about the equinoctial axis). In fact, since we were able to interpret the region of definition of the discrepancies as a tube in the orthogonal group, and since the minimum discrepancy of latitude is attained (by hypothesis) on a whole arc parallel to the axis of the tube, consequently, relying on known facts about the structure of the orthogonal group, we can resolve the transformations $g(t, \beta, \gamma)$ uniquely into a composition of elementary rotations coinciding with the rotations of the celestial sphere described above in a neighborhood of the boldface arc. It is important to note that the a priori minimum of discrepancy can be attained on an arbitrary arc inside M .

Thus we have justified the following proposition.

Proposition. *Assume that as a result of the numerical analysis of a specific star catalog, as described above, the following facts are discovered:*

- the values β_0 and γ_0 found coincide with those determined by the method of Sec. 6;
- the minimum discrepancy in latitude is attained strictly inside the tube M on a curve parallel to the axis of the tube;
- this minimum does not exceed the smallest division Δ of the scale of the catalog, i.e., the precision claimed by the observer for his measurements. We then

1) confirm the assertion of the author of the catalog about the precision of his measurements, since we indeed discover a list of bright named stars measured with the claimed precision and forming the major part of a complete list of named stars;

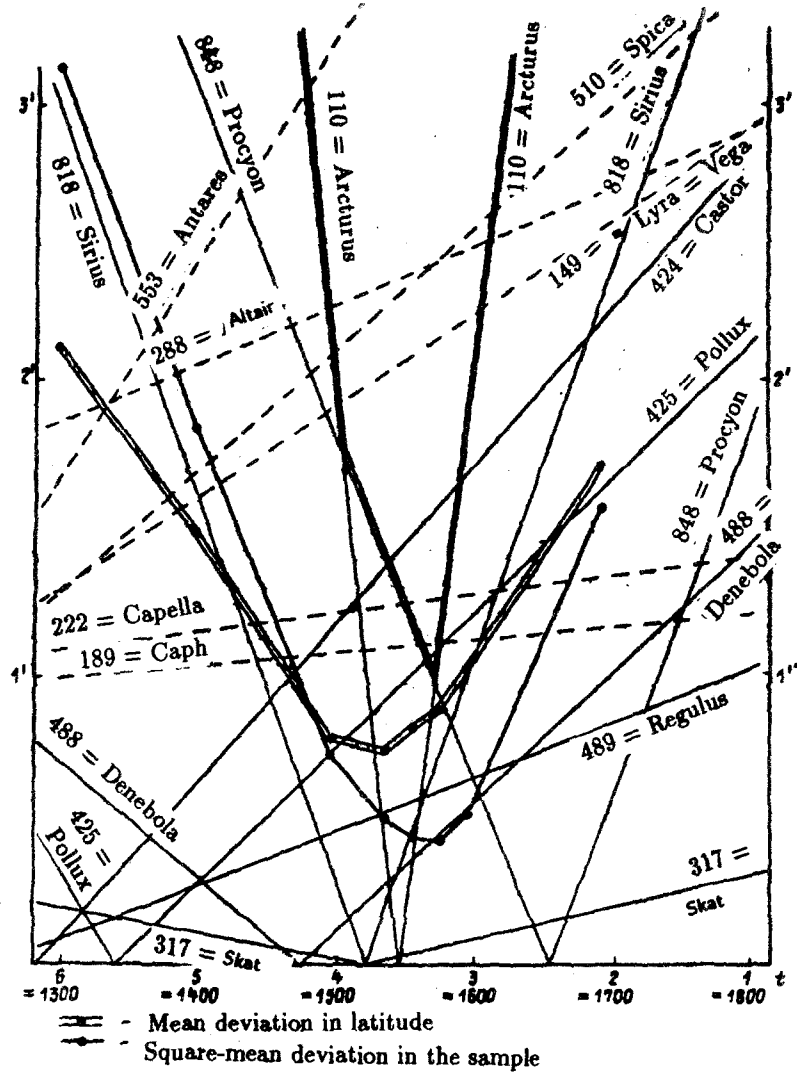

Fig. 3. Individual discrepancies in latitude for Tycho Brahe (with $\gamma = 0$).

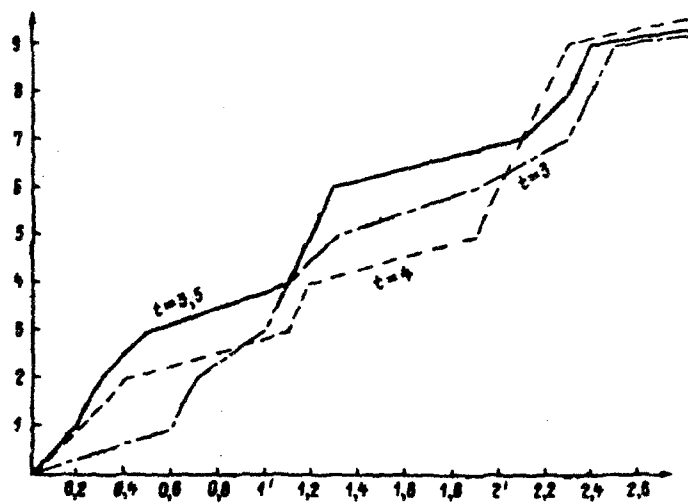

Fig. 4. The cumulative histogram for Tycho Brahe. Optimal $t^* = 3.5$.

- 2) we determine an interval of time within which the measurements were carried out and outside of which (assuming the claimed and confirmed precisions are fixed) the catalog could not have been compiled;
- 3) we prove that the mechanism for measuring ecliptic coordinates coincides with the one described

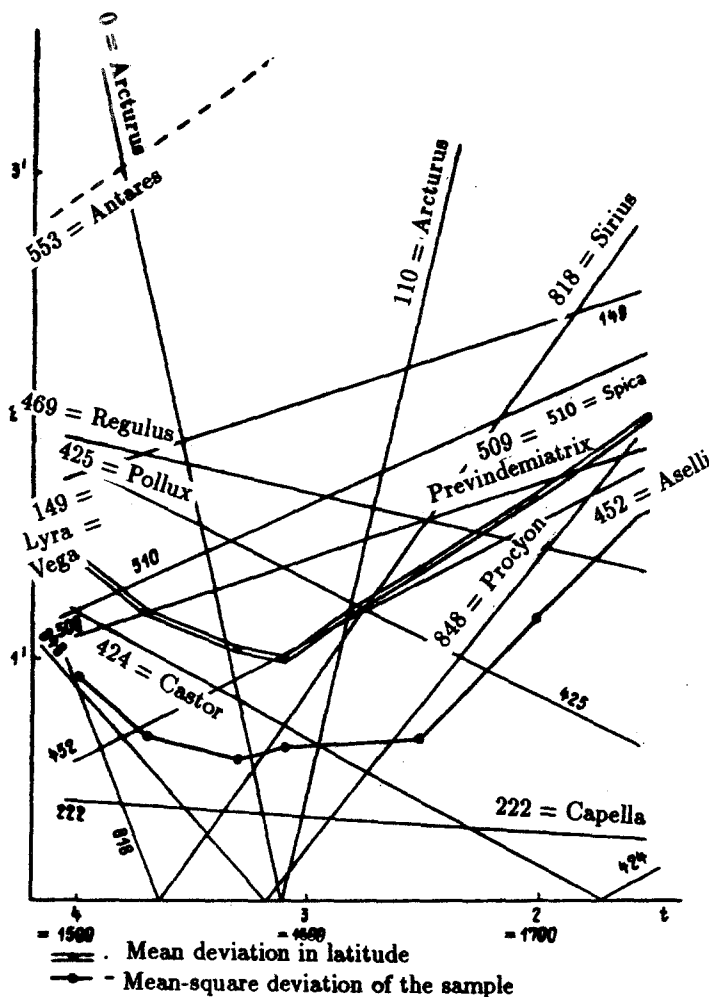

Fig. 5 Individual discrepancies in latitudes for Hevelius.

above, i.e., we “restore” the method of measuring the stars;

4) we calculate the actual errors β_0 and γ_0 made by the observer;

5) we differentiate the catalog and its informational kernel with respect to the precision of measurement, i.e., we exhibit the well-measured and badly-measured stars.

Remark. A catalog can be dated in this way, even in the case when there are no stars in its informational kernel with observable proper motion (since the oscillations of the ecliptic, which vary the latitudes of the stars, are taken into account).

8. The dating of Tycho Brahe’s catalog

We used the edition [8] of Tycho Brahe’s catalog that was current at the end of the 16th century. The catalog in [8] is based on an epochal year 1600. The informational kernel of the catalog was taken to be 14 bright named stars: Arcturus (110), Spica (510), Lyra-Vega (149), Altair (288), Antares (553), Castor (424), Sirius (818), Pollux (425), Procyon (848), Denebola (488), Capella (222), Caph (189) Regulus (469), and Skat (317). These are not all the named stars in the catalog, but the majority of them coincide with the *Almagest* and it is interesting to compare their results with Tycho Brahe’s catalog.

The individual discrepancies in latitude for these stars under the optimal values of the parameters $\beta = 0$, $\gamma = 0$ (determined by us—cf. Sec. 6.4) are presented in Fig. 3. It is clear that the precision claimed by Tycho Brahe of 1' is greatly exaggerated, even for the prominent named stars. The actual precision in latitude for the given sample is 3'. Taking $\Delta = 3'$, we obtain formally two solutions on the a priori interval $0 \leq t \leq 6$: $T_2 = [4, 5]$ (from 1400 to 1500) and $T_2 = [2\frac{4}{5}, 3]$ (from 1500 to 1620). The first solution is obtained by rejecting Arcturus, the second by rejecting Antares. The second solution is preferable to

the first, since the minimum average discrepancy $\bar{\Delta}_E(t)$ and sample variance $\sigma_E^2(t)$ are attained on it; in addition, a smaller value of $\Delta_b(D)$ corresponds to this sample than to the first (cf. [11], [12], [15]). The traditional dating of approximately 1580 lies in this interval. We note that by taking $3 \leq t \leq 4$ (the sixteenth century) as an a priori interval we obtain a unique solution for $\Delta = 1'$ (the precision claimed by Tycho Brahe): the year 1580 ± 10 (cf. Fig. 3). The optimal value t^* obtained by comparing the distribution functions of the errors (10) is $t^* = 3.5$ (about 1550, cf. Fig. 4).

9. The catalog of Hevelius

We borrowed the catalog of Hevelius from [8]. The traditional date of this catalog is the second half of the 17th century. As the informational kernel we took basically the same stars as for the catalog of Tycho Brahe (cf. Fig. 5): Arcturus (110), Spica (510), Vega (149), Aselli (452), Antares (553), Castor (424), Sirius (818), Pollux (425), Procyon (848), Capella (222), Regulus (469), Previandematrix-Vindematrix (509) (12 stars altogether). The optimal values of the parameters γ and β turned out to be: $\gamma = 0$, $\beta = 0$. The individual discrepancies in latitude for these values on the interval $1 \leq t \leq 4$ are presented in Fig. 5. It is abundantly clear that the actual precision of the latitudes in the catalog is about $2'$ (with a scale divided into intervals of size $1''$). The interval T_2 (cf. Sec. 6.5) becomes stable under small variations Δ for $\Delta \geq 2.2'$. Thus for $\Delta = 2.5'$ it is the interval $2.5 \leq t \leq 3.0$ (1540–1650), and for $\Delta = 3'$ it is the interval $2.35 \leq t \leq 3.85$ (1515–1665). The optimal value of the date when comparing the distribution functions of the errors (cf. (10)) is $t^* = 3 \pm 0.5$. Evidently Hevelius, together with his own observations, used some data from already existing catalogs (Tycho Brahe's?).

10. Artificial catalogs

We compiled several artificial catalogs by computing the modern coordinates of stars for epochs t_1, t_2, \dots (taking account of proper motions) and modeling the systematic (γ, τ) and random errors of a catalog (in doing so we assumed $\beta = 0$). In modeling the random errors we sometimes used a sample from a homogeneous, normally distributed collection (Catalog No. 1) and sometimes divided the stars into “precisely-measured” and “spurious” (Catalogs Nos. 2 and 3). In all the cases studied the solution obtained (the interval T_2 , cf. Sec. 6.5) covered the true date. When this was done, a non-unique solution was obtained in the first case (Catalog No. 7). In modeling by the second method (Catalogs Nos. 2 and 3) we obtained unique solutions. Moreover the method of discovering the true value of the date of the observations by comparing the distribution functions for the errors (cf. (10)) was confirmed, as was the method of determining the values of the parameters γ and τ (cf. Sec. 6.4).

11. The dating of the *Almagest*

The informational kernel of the *Almagest* consists of 12 stars (see the preliminary analysis of the catalog in Sec. 5). We denote it by Z . Application of the method of Sec. 6.4 made it possible to determine the optimal values of the parameters γ and β : $\gamma = 20'$, $\beta = 0$. As was noted above, the values obtained for γ and β are in agreement with the existing studies of the *Almagest* (cf. [1] and [9]). To compare these values with the values $\gamma = \beta = 0$, we present a table similar to Table 1, but computed for $\gamma = 20'$, $\beta = 0$.

We took Δ to be $10'$ —the claimed precision of the *Almagest*. It is evident from Table 2 that for $6 \leq t \leq 12$ the quantity $|B_i(t) - b_i|$ is at most $10'$ for 8 of the 12 stars. Moreover, for the other four stars the discrepancy in latitude $|B(t) - b|$ never gets as low as $10'$ on the entire a priori interval (i.e., for these stars the inequality $\min_{0 \leq t \leq 25} |B(t) - b| > 10'$ holds). Two of these four stars are demonstrably “spurious”: one of them (Canopus) is too far south and its coordinates are significantly affected by refraction. The other (Previandematrix) has coordinates that are off by several degrees in all lists and editions of the *Almagest*, and the coordinates of it given in [1] are practically unsupported by any original sources (cf. [1], p. 104).

Table 2

	1	5	10	15	18	21
110	29.9	15.5	2.3	20.0	30.5	41.0
818	44.2	39.2	32.7	25.9	21.8	17.5
288	27.0	28.7	30.7	32.5	33.5	34.4
509	15.6	14.9	13.8	12.6	11.8	11.0
553	13.3	11.0	8.5	6.2	4.9	3.7
452	13.2	10.2	6.5	2.9	0.9	1.1
848	8.1	4.0	1.2	6.7	10.1	13.5
469	6.1	3.5	0.4	2.7	5.1	6.2
510	5.1	4.9	4.4	3.7	3.3	2.7
149	5.1	6.7	8.5	10.0	10.8	11.5
222	1.3	1.5	2.1	2.9	3.5	4.2
892	71.5	75.0	79.2	83.1	85.4	87.6

Fig. 6 gives the graphs of the individual discrepancies of the stars in list Z . The dashed lines indicate the discrepancies of stars that do not fall within the $10'$ level anywhere on the a priori interval $0 \leq t \leq 25$ (Canopus is not shown, since its discrepancy generally falls outside the limits of the figure). The discrepancies are computed for $\gamma = 20'$, $\beta = 0$. It is curious to note that the latitudinal discrepancy for Arcturus (the brightest star in the southern hemisphere) vanishes for $t = 8.5$ (the year 1050 C. E.); for Regulus (one of the most important stars in ancient astronomy; Ptolemy measured its coordinates several times by different methods, cf. [3]) it vanishes for $t = 10.5$ (the year 850 C. E.); and for Procyon it vanishes for $t = 9.5$ (the year 950 C. E.). This is the only accumulation of zero discrepancies (cf. Fig. 6).

The comparison of the distribution functions is shown in Fig. 7.

Fig. 8 gives the graph of $\Delta_b(D, t)$ (cf. Sec. 7), where D is the kernel Z with the 4 spurious stars removed: Canopus, Previandematrix, Altair, and Sirius. It is readily apparent that the "flat shelf of the minimum" of this graph drops below the $10'$ level in the interval from $t = 12$ to $t = 6$. Outside the limits of this interval the graph begins to increase rapidly. Fig. 8 also shows the graphs of the values $\gamma(t)$ and $\beta(t)$ at which the minimum discrepancy is attained (cf. (14)).

Thus we have obtained a result that amounts to the following: 1) It turns out that the $10'$ precision claimed by the author of the *Almagest* was indeed attained by him for the majority of named stars. We have found a list of 8 stars whose latitudes were measured in the *Almagest* with $10'$ precision: Arcturus, Regulus, Spica, Procyon, Capella, Lyra (Vega), Antares, and Aselli. 2) When the claimed $10'$ precision of the catalog for the latitudes of the named stars is fixed, the catalog could not have been compiled outside the time interval $t = 12$ to $t = 6$, i.e., from 700 C. E. to 1300 C. E. In particular the catalog could not have been compiled in the 2nd century C. E. or in the 2nd century B. C. E. 3) Since conditions a) and b) of Sec. 7 happen to hold for the *Almagest*, the mechanism of measuring the coordinates of the stars in the *Almagest* coincides with that described above (equatorial coordinates were first measured and then converted to ecliptic coordinates). 4) The author of the *Almagest* made practically no error in locating the equator, since the optimal value of β turned out to be zero. 5) The author of the *Almagest* erred by $20'$ in determining the position of the pole of the ecliptic, i.e., $\gamma = 20'$ (cf. Sec. 6.2). 6) The informational kernel of the *Almagest*, consisting of named stars (there are 12 of them), contains 8 well measured stars and 4 spurious ones: Canopus, Previandematrix (ϵ Vir), Altair (α Aql), and Sirius. Here the error in the

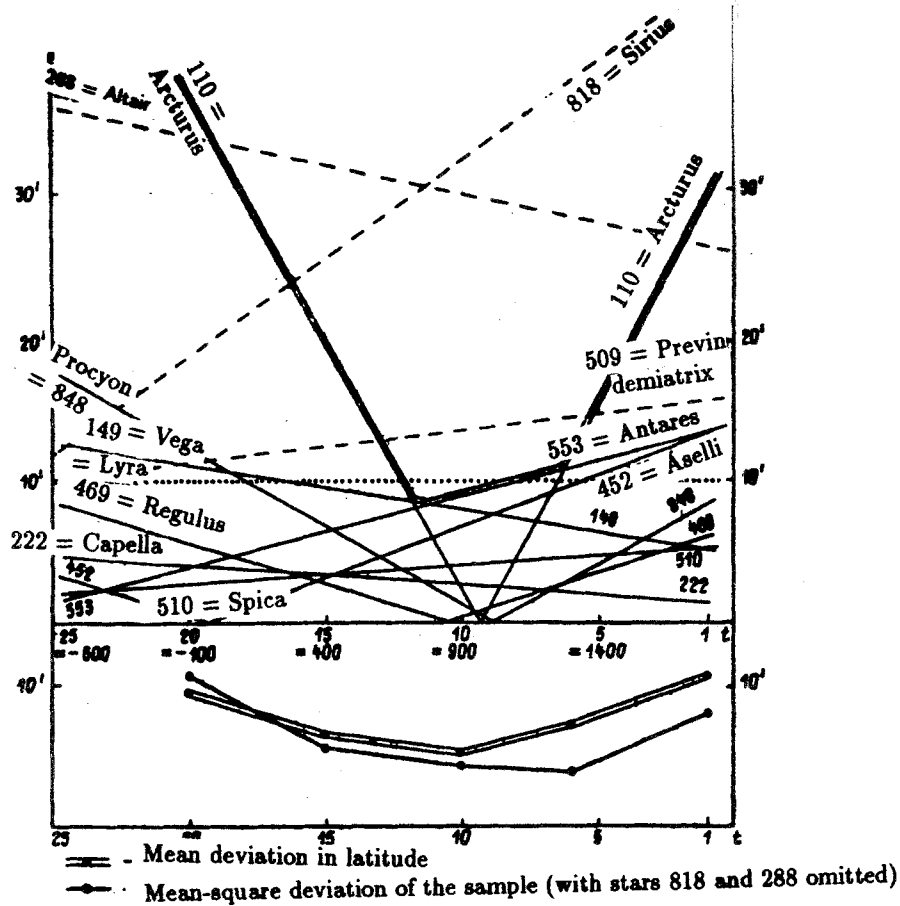

Fig. 6. Individual discrepancies in latitudes for the *Almagest* (for $\beta = 0$, $\gamma = 21$) with respect to 12 bright named stars (Canopus-892 is not shown, since there are large errors in its measurement).

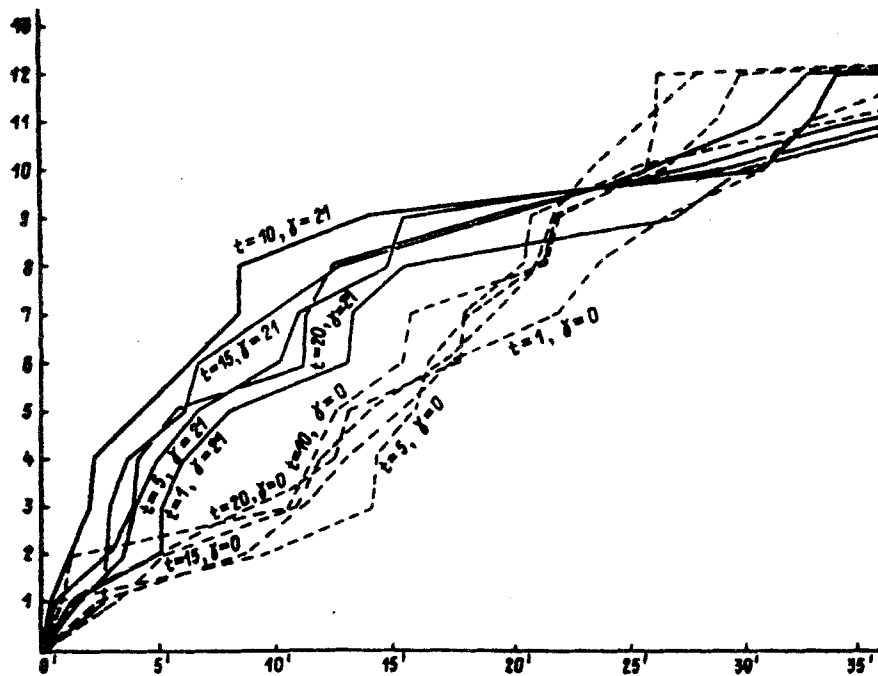

Fig. 7. The cumulative histograms for the *Almagest* with respect to 12 bright named stars for $t = 1, 5, 10, 15, 20$. The solid lines are $\gamma = 21$; the dashed lines are $\gamma = 0$.

latitude of Canopus (and evidently of Sirius) is caused by refraction, the latitude of the star ϵ Vir evidently contains a copying error, and Altair lies far from the other 11 stars of the kernel Z in a part of the sky

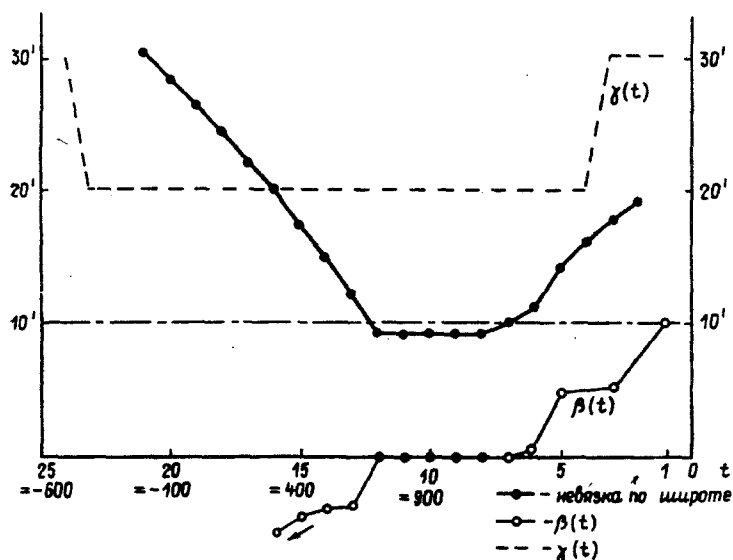

Fig. 8. The graph of the latitude discrepancy for 8 stars of the *Almagest* with variable β and γ .

that the author of the *Almagest* apparently observed very badly (along with Altair he shows the star α Pis Aust twice under the numbers 670 and 1011 with latitudes that differ by more than 2° , cf. [1], p. 113). Increasing the level of Δ to $15'$ does not contradict the date obtained (for $\Delta = 10'$). When this is done, the interval enlarges only slightly (cf. Fig. 6). Moreover the minimum discrepancy in latitude still remains in the interval 700–1300 C. E.

The authors are sincerely grateful to V. M. Zolotarev and V. G. Demin for critical comments and valuable advice. They also thank T. S. Turova, O. Yu. Soboleva, and Yu. A. Tyurina for valuable assistance in processing numerical data and Yu. G. Fomin for consultation and assistance in working with the computer.

Literature Cited

1. C. H. F. Peters, and E. B. Knobel, *Ptolemy's Catalogue of Stars. A Revision of the Almagest*, The Carnegie Institute of Washington (1915).
2. V. B. Gurevich, *Introduction to Spherical Astronomy* [in Russian], Nauka, Moscow (1978).
3. R. Newton, *The Crime of Claudius Ptolemy*, Johns Hopkins University Press, Baltimore (1977).
4. S. N. Blazhko, *A Course of Practical Astronomy* [in Russian], Nauka, Moscow (1979).
5. Yu. A. Karpenko, *Celestial Names* [in Russian], Nauka, Moscow (1981).
6. H. Kinoshita, *Formulas for Precession*, Smithsonian Inst. Astrophys. Obs., Cambridge, MA, February 28, 1975.
7. W. Fricke and A. Koff, *FK4*, Veroff. Astr. Inst. Heidelberg, No. 10 (1963).
8. F. Bailey, "The catalogues of Ptolemy, Ulugh Beigh, Tycho Brahe, Halley, and Hevelius, deduced from the best authorities," *Roy. Astr. Soc. Memoirs*, XIII, 1–248 (1843).
9. N. A. Morozov, *Christ* [in Russian], Vol. 4, GIZ, Moscow-Leningrad (1928),
10. A. T. Fomenko, "On the properties of the second derivative of the lunar elongation and the statistical regularities connected with it," *Vopr. Vych. Prik. Mat.*, Sovet Akad. Nauk Uzb. SSR, No. 63, 136–150 (1981).
11. A. T. Fomenko, "The jump of the second derivative of the Moon's elongation," *Celestial Mechanics*, 29, 33–40 (1981).
12. A. T. Fomenko, "Computation of the second derivative of the lunar elongation and the statistical regularities in the distribution of certain astronomical data," *Issled. Oper. ASU*, Kiev Univ. Press, No. 20, 98–113 (1982).
13. A. T. Fomenko, "A new empirical-statistical method of arranging texts and applications to dating problems," *Dokl. Akad. Nauk SSSR*, 268, No. 6, 1322–1327 (1983).
14. A. T. Fomenko, "A method of detecting duplicates and certain applications," *Dokl. Akad. Nauk SSSR*, 258, No. 6, 1326–1330 (1981).

15. A. T. Fomenko, "New empirico-statistical dating methods and statistics of certain astronomical data," in: *Proceedings of the First World Congress of the Bernoulli Society of Mathematical Statistics and Probability Theory*, Vol. 2, Nauka, Moscow (1986), p. 892.
16. A. T. Fomenko, "A new empirical-statistical method of detecting parallelisms and dating duplicates," *Probl. Ustoich. Stokh. Mod: Tr. Sem.*, 154–177, VNIISI, Moscow (1984).
17. A. T. Fomenko, "Detecting dependences and stratified structures in narrative texts," *Probl. Ustoich. Stokh. Mod: Tr. Sem.*, 115–128, VNIISI, Moscow (1987).
18. A. T. Fomenko, "New experimental-statistical methods of dating ancient events and applications to the global chronology of the ancient and medieval world," Preprint: Gos. Kom. Telev. Radio., No. B7201 (1981).
19. Yu. N. Efremov and E. D. Pavlovskaya, "Dating of the *Almagest* by the proper motions of stars," *Dokl. Akad. Nauk*, **294**, No. 2, 310–313 (1987).